

R1 Example: Reinforced Brickwork Pocket-Type Retaining Wall

A reinforced brickwork earth retaining wall 3,65m high has to support a graded sand and gravel backfilling with drainage. The brick format masonry units are Group 1 and have a compressive strength (non-normalised) of 50N/mm^2 being laid in a class M12 General Purpose mortar. Bricks are Category I with Class 1 Execution Control of the works. The main reinforcement is grade 500 high yield deformed steel bars placed in formed vertical voids (pockets) with a C35/45 structural concrete infilling. The foundation will be a reinforced concrete spread type. The retained soil lies horizontal at the wall head with no applied surcharge other than that expected from nominal incidental loads and for which allowance has been made in the design loadings.

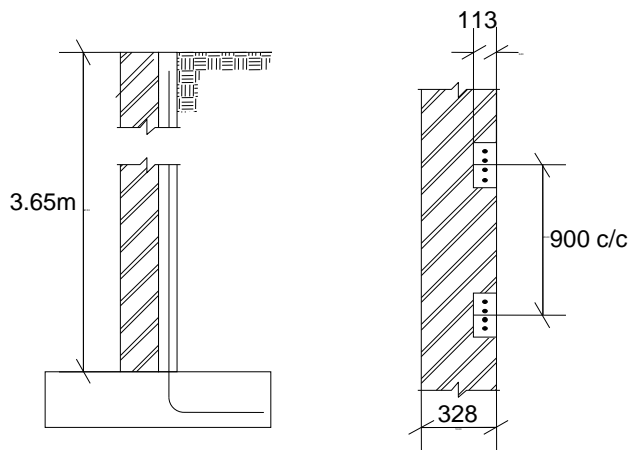

Figure 1: Elevation and plan of the reinforced wall