

DESIGN EXAMPLE V6

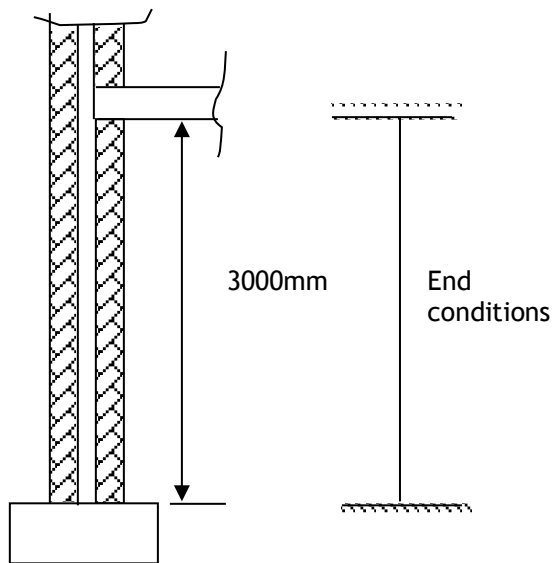

Taking Design Example 3 for the lower lift of the inner loadbearing leaf of a 4-storey cavity wall, it is now required to carry a horizontal wind suction design loading of $1,0 \text{ kN/m}^2$ in addition to the 130 kN/m design vertical loading as before. The Group 1 concrete block masonry units have a compressive strength of $7,3 \text{ N/mm}^2$ ($9,5 \text{ N/mm}^2$ normalised compressive strength).

Re-calculate the vertical load capacity of the wall inner leaf loadbearing concrete blockwork to assess that it can carry the vertical design load under these revised loading conditions.

Recalculate the vertical load capacity of the wall inner loadbearing leaf using Group 1 clay brick masonry units with a compressive strength of 50 N/mm^2 ($42,5 \text{ N/mm}^2$ normalised compressive strength) with the loadbearing leaf constructed in $102,5 \text{ mm}$ thickness brickwork.

Helpful Tip:

The bending moments of a single span encastre member with ud loading are $WL/12$ at end supports and $WL/24$ at centre of span.