

DESIGN EXAMPLE V1

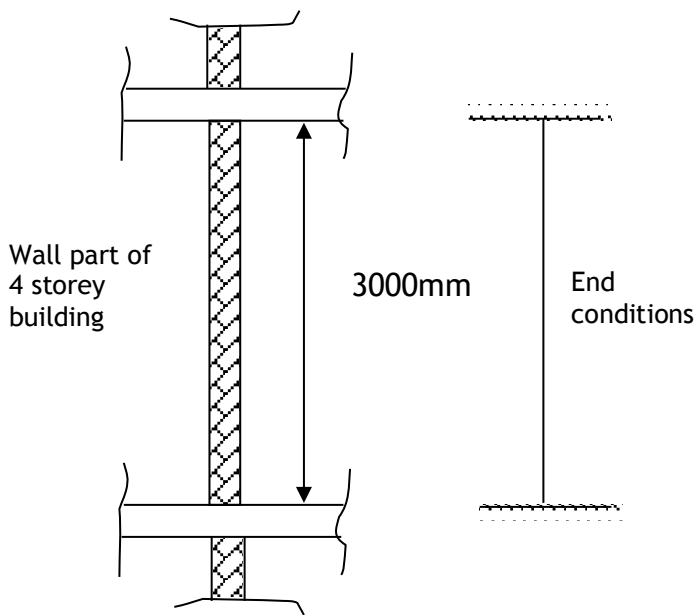

Design vertical load = 180 kN/m with no applied eccentricity of loading

Find the characteristic strength (f_k) of masonry made from Group 1 clay brick masonry units of standard format size (width 102,5mm) with a normalised compressive strength (f_b) of 42,5 N/mm². The attestation of conformity (manufacturing control) is Category II and the masonry will be constructed using an M4 general purpose mortar using Class 2 execution control. Check that the load capacity of such a wall is sufficient to withstand the loading applied.

Recalculate the above using Group 1 concrete block masonry units with a normalised compressive strength (f_b) of 20 N/mm². The masonry units are 140mm in thickness.

Ignore the self weight of the wall.